

SPECIFICATIONS



BELL 525





Publisher's Notice

The information herein is general in nature and may vary with conditions. Individuals using this information must exercise their independent judgment in evaluating product selection and determining product appropriateness for their particular purpose and requirements. For performance data and operating limitations for any specific mission, reference must be made to the approved flight manual. Bell Helicopter Textron Inc. makes no representations or warranties, either expressed or implied, including without limitation any warranties of merchantability or fitness for a particular purpose with respect to the information set forth herein or the product(s) and service(s) to which the information refers. Accordingly, Bell Helicopter Textron Inc. will not be responsible for damages (of any kind or nature, including incidental, direct, indirect, or consequential damages) resulting from the use of or reliance on this information. Bell Helicopter Textron Inc. reserves the right to change product designs and specifications without notice.

© 2019 Bell Helicopter Textron Inc.

All registered trademarks are the property of their respective owners.

Table of Contents

The Bell 525 Commercial Helicopter	1
Preliminary Specification Summary (U.S. Units)	4
Preliminary Specification Summary (Metric Units).....	5
Helicopter Dimensions.....	6
Garmin G5000H™ Avionics Flight Deck.....	8
Pursuit of Safety through Technology	13
Bell 525 Maintenance Program	14
Seating and Interior	15
Mission Profiles.....	17
Bell 525 Standard Configuration.....	18
Bell 525 Kits.....	20
Customer Support and Services.....	24
Training	29
Aeronautical Accessories.....	33

The Bell 525 Commercial Helicopter

BELL 525 OVERVIEW

The Bell 525 Relentless is the latest-generation commercial twin-engine helicopter. The Bell 525 is powered by two electronically-controlled GE CT7-2F1 engines that deliver exceptional performance along with a maximum cruise speed of 160 kts (296 kph). A state of the art fly-by-wire flight control system delivers an unparalleled flying experience with the ability to operate in harsh environments reliably while greatly reducing pilot work load. Garmin G5000H flight deck provides critical flight information for crews at-a-glance, offering unparalleled situational awareness and safety.

The speed, performance, reliability and maneuverability of Bell 525 is integrated with a flat floor and open cabin, configurable for a wide variety of missions and payloads. Examples include; 16 PAX OGP transport, Search and Rescue, Corporate and VIP interiors. The spacious cabin can be configured to carry up to 19 passengers in an FAA certified configuration and additional passengers for parapublic missions. Passenger comfort is enhanced with a quiet and smooth ride provided by the four LIVE® transmission mounts which isolate main rotor vibrations before they enter the airframe. The optional Bell Active Vibration Control System also helps to ensure a smooth ride throughout the flight regime.

The Bell 525 is designed based on direct input from a panel of customer advisors representing expertise in all facets of the helicopter industry. The Customer Advisory Panel has participated in the aircraft design process since 2010 and has provided critical input to the following areas:

- Baggage capacity and access
- Engine and avionics suppliers
- Kit configurations
- Maintenance access
- Fleet integration
- Training requirements
- Operating economics
- Payload range capability
- Commitment to Cat A performance
- Cockpit integration and situational awareness
- Effective egress
- Corrosion averse design
- Cabin comfort
- Repairability

The platform will be certified to the most recent FAA and EASA Part 29 regulations as well as the first helicopter to be certified to the latest MSG-3 standards (2013.1 Version 2).

Bell's products are backed by our renowned in-service support, voted #1 by our customers for 23 consecutive years. The Bell 525 proves you don't have to sacrifice comfort for performance.



World's Most Advanced Commercial Helicopter

BELL'S NEW COMMERCIAL HELICOPTER

Bell 525 Fly-by-Wire Flight Controls: The Bell 525 Relentless features the fully integrated Garmin G5000H flight deck coupled with an advanced fly-by-wire flight control system that provides unparalleled crew situational awareness, resulting in enhanced safety levels and mission capabilities. The cockpit controls are ergonomically designed side sticks made to decrease pilot workload, and when combined with the full time 4-axis stabilization, creates a whole new way to fly. The aircraft systems are fully-integrated with the Garmin G5000H avionics suite to display critical flight instruments, autopilot modes, hold references, audio alerts and CAS messages.



The Garmin G5000H flight deck provides the next level of safety.

World's Most Advanced Commercial Helicopter

BELL 525 FLY-BY-WIRE FLIGHT CONTROLS

As the first commercially-certified fly-by-wire (FBW) helicopter, the Bell 525 is the future of safety. Bell has over 25 years experience in fly-by-wire flight control design on the highly successful V-22 Osprey. The proprietary in-house designed control laws are meant to assist the pilot and substantially reduce pilot workload. The FBW control architecture takes advantage of advanced control law modes while enhancing the level of safety over that of the conventional mechanically controlled helicopter. The pilot is always in command and can easily maintain flight conditions as well as make smooth transitions between conditions by directly commanding the control axes. The Bell 525 FBW control laws increase pilot situational awareness especially for the low speed/low altitude and degraded visual environment (DVE) conditions that are critical segments of the helicopter oil & gas, SAR, HEMS, and fire fighting missions.

The always active FBW control holds are there when you need them, while the pilot is always in direct control of the aircraft. The feature acts like a “smart-autopilot,” always remembering the pilots last input, making flying repeatable, simple, and intuitive. There are many features to the Bell 525 FBW control system that increase safety and truly differentiate it from the competition including:

- Full Time Control Holds
- High Rate of Descent Protection
- Full Time 4 axis Stabilization
- Autorotation Entry Assist
- Automatic Hover Hold
- Automatic Bank Angle Holds
- Collective Tactile Cueing
- Precise Flight Control “Beeping”
- Automatic Hover and Transitions in OEI
- Control Axis Decoupling

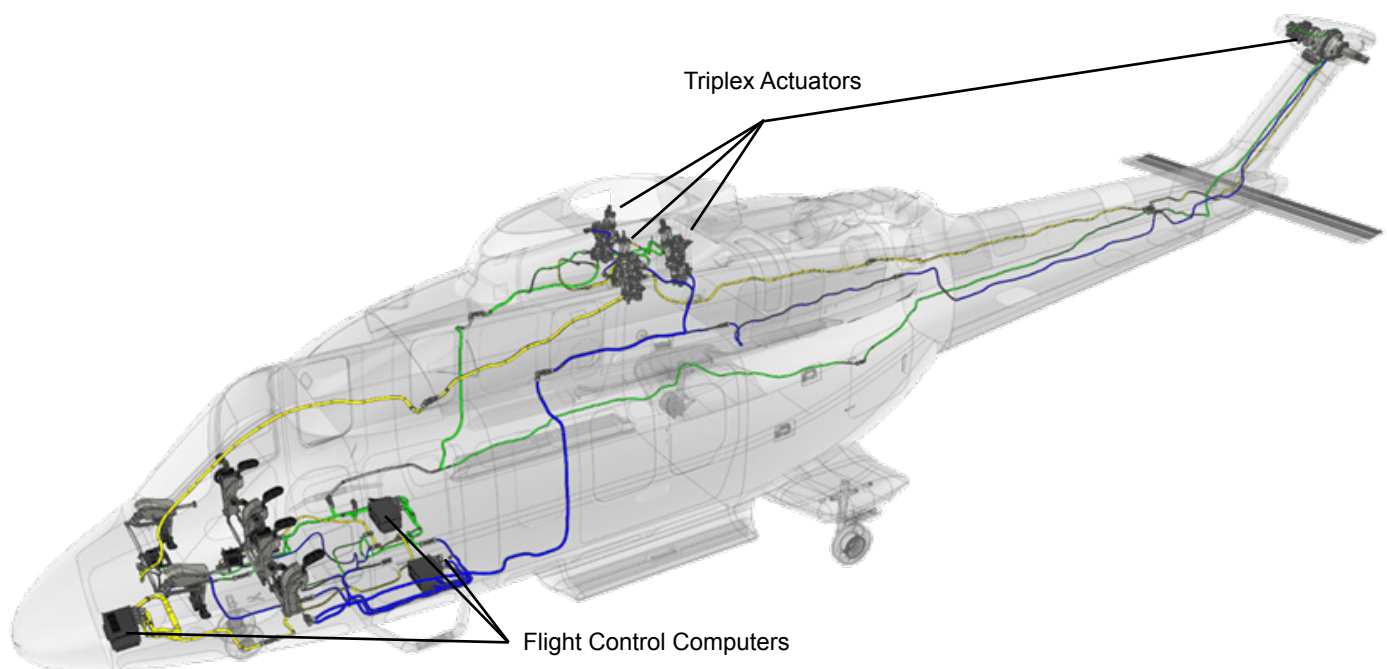

Preliminary Specification Summary (U.S. Units)

WEIGHTS (lb)

Empty Weight (Offshore Transport Equipped)	13,825	External Load Gross Weight	21,500
Internal Gross Weight	20,500	Maximum External Load (Cargo Hook Limit)	7,000

PERFORMANCE SUMMARY (International Standard Day except as noted)

			Takeoff Gross Weight (lb)		
			18,000	19,000	20,500
IGE Hovering Ceiling ^[1]	ISA	ft	12,000	12,000	10,700
	ISA + 20 °C	ft	12,000	10,400	8,100
	ISA + 30 °C	ft	10,300	8,700	6,100
OGE Hovering Ceiling ^[1]	ISA	ft	11,900	10,300	8,100
	ISA + 20 °C	ft	9,300	7,600	5,100
	ISA + 30 °C	ft	7,500	5,600	2,800
Initial Service Ceiling (MCP) ^[2]		ft	12,000	12,000	12,000
Maximum Cruise Speed (True Airspeed)	SL, ISA	ktas	164	163	160
	SL, ISA + 20 °C	ktas	163	161	159
Range (Standard Fuel, No Reserve)	SL, ISA	nmi	600	595	580
LRC Speed (Average True Airspeed)		ktas	145	145	145
Range (Standard Fuel, No Reserve)	4,000 ft, ISA	nmi	665	655	635
LRC Speed (Average True Airspeed)		ktas	145	145	145
Never Exceed Speed (True Airspeed) ^[3]		ktas	175	175	175

ENGINE RATING

GE CT7-2F1 with Full Authority Digital Electronic Control:	
Takeoff Horsepower (Uninstalled Thermodynamic Capability)	1,979 SHP
Maximum Continuous (Uninstalled Thermodynamic Capability)	1,714 SHP
30-second OEI Capability	2,129 SHP

FUEL CAPACITY (usable)

Standard	641 US Gallons
----------	----------------

Notes: [1] Values limited to expected maximum certification altitude.
 [2] Density Altitude

Preliminary Specification Summary (Metric Units)

WEIGHTS (kg)

Empty Weight (Offshore Transport Equipped)	6,270	External Load Gross Weight	9,752
Internal Gross Weight	9,299	Maximum External Load (Cargo Hook Limit)	3,175

PERFORMANCE SUMMARY (International Standard Day except as noted)

			Takeoff Gross Weight (kg)		
			8,165	8,618	9,299
IGE Hovering Ceiling ^[1]	ISA	m	3,658	3,658	3,261
	ISA + 20 °C	m	3,658	3,170	2,469
	ISA + 30 °C	m	3,139	2,652	1,859
OGE Hovering Ceiling ^[1]	ISA	m	3,627	3,139	2,469
	ISA + 20 °C	m	2,835	2,316	1,554
	ISA + 30 °C	m	2,286	1,707	853
Initial Service Ceiling (MCP) ^[2]		m	3,658	3,658	3,658
Maximum Cruise Speed (True Airspeed)	SL, ISA	km/h	304	302	296
	SL, ISA + 20 °C	km/r	302	298	294
Range (Standard Fuel, No Reserve)	SL, ISA	km	1111	1102	1074
LRC Speed (Average True Airspeed)		km/h	269	269	269
Range (Standard Fuel, No Reserve)	1219 m, ISA	km	1232	1213	1176
LRC Speed (Average True Airspeed)		km/h	269	269	269
Never Exceed Speed (True Airspeed)	1219 m, ISA	km/h	324	324	324

ENGINE RATING

GE CT7-2F1 with Full Authority Digital Electronic Control:	
Takeoff Horsepower (Uninstalled Thermodynamic Capability)	1,476 kW
Maximum Continuous (Uninstalled Thermodynamic Capability)	1,278 kW
30-second OEI Capability	1,588 kW

FUEL CAPACITY (usable)

Standard	2,426 Liters
----------	--------------

Notes: [1] Values limited to expected maximum certification altitude.

[2] Density Altitude

Helicopter Dimensions

EXTERNAL DIMENSIONS

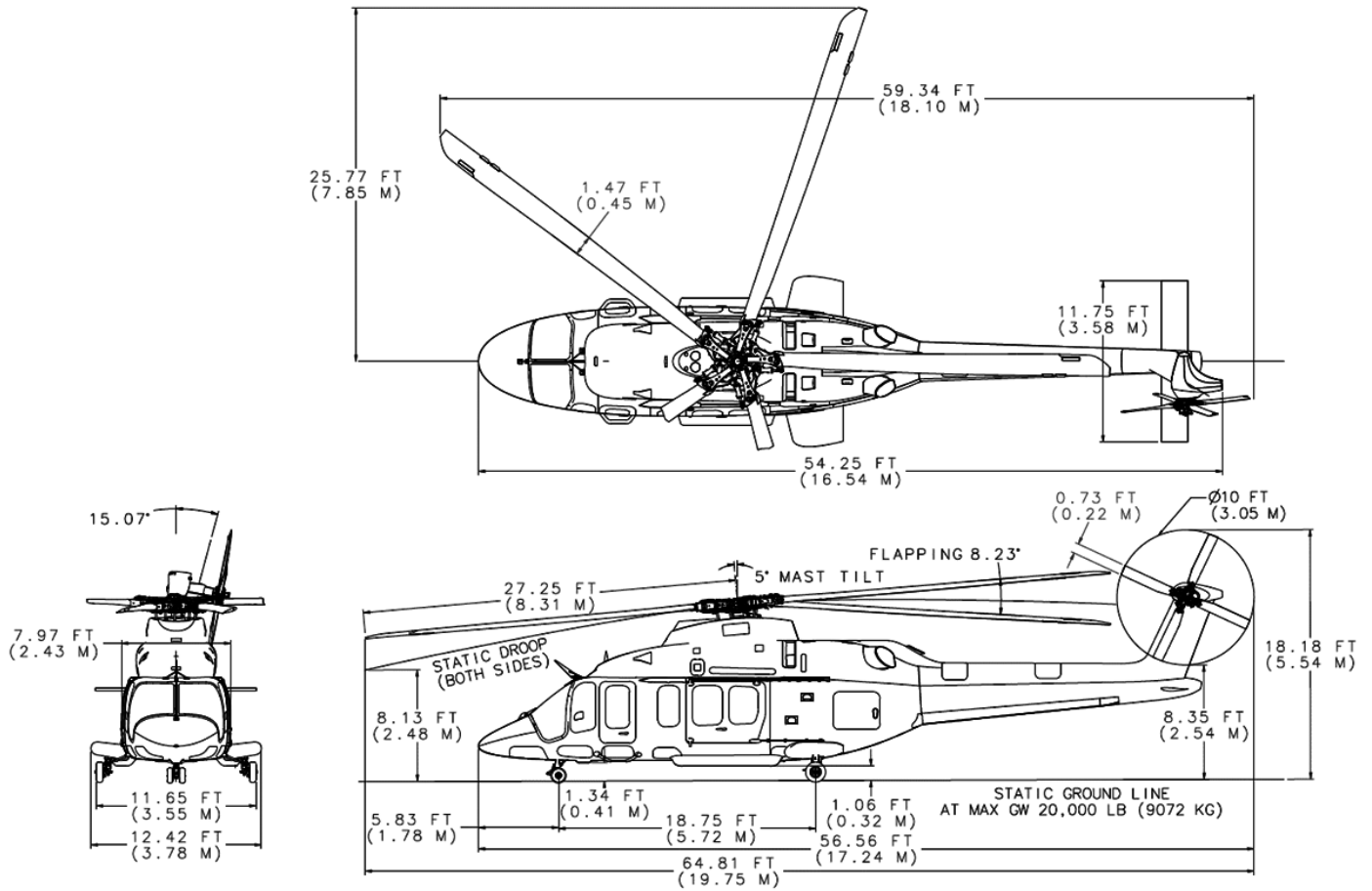

LANDING GEAR LOADING

CG Position		Loading		Contact Area		Contact Pressure	
		lb	kg	in ²	cm ²	lb/in ²	kg/cm ²
Forward	FWD	6,195.6	2,810.3	20.65	133.2	150	10.5
	AFT	7228.8	3278.9	29.72	191.7	272	19.1
Aft	FWD	4,555.6	2,066.4	15.19	98.0	150	10.5
	AFT	8048.8	3650.9	32.37	208.8	272	19.1

Note: Preliminary landing gear loading at maximum gross weight (20,500 lb [9,299 kg]) based on 1G static conditions for both flight CG limits.

Helicopter Dimensions

INTERNAL DIMENSIONS

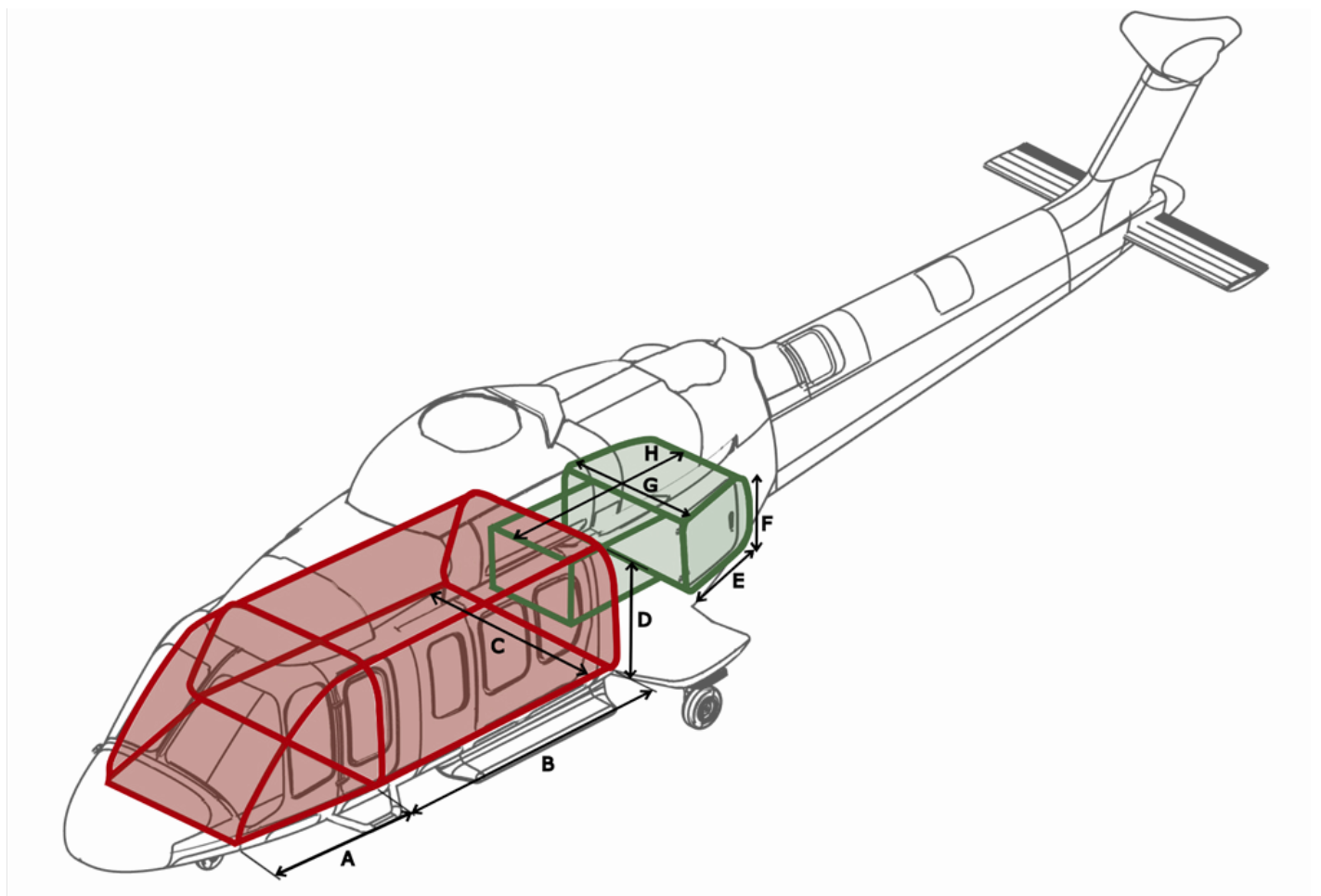

Dimension *	in	cm
A	36	91
B	150	381
C	91	231
D	54	137
E	39	99
F	31	200
G	79	269
H	106	269

Cargo space *	US Units	Metric
Cabin surface area	88 ft ²	8.2 m ²
Baggage compartment volume	128 ft ³	3.6 m ³
Floor Loading *		
Cabin	85 lb/ft ²	415 kg/m ²
Baggage	75 lb/ft ²	366 kg/m ²
Maximum baggage weight	2,000 lb	907 kg

NOTE: * Volumes and dimensions are approximate.

Garmin G5000H™ Avionics Flight Deck

The Bell 525 Relentless is the first commercial helicopter to incorporate the Garmin G5000H™, a touchscreen avionics suite. The Garmin G5000H™ is designed to improve situational awareness and reduce pilot workload through easy to read displays of critical flight information, tuning of communication and navigation frequencies, and simple flight planning management.

The Bell 525's standard configuration G5000H™ Flight Deck includes the Helicopter Synthetic Vision Technology (HSVT) that gives pilots a 3D depiction of terrain, obstacles, traffic and more in any visibility condition. The Primary Flight Display (PFD) provides critical flight information in a centralized location and boasts a Power Situation Indicator (PSI) that is similar to that in the G1000H™ on the Bell 407GXP. The system has two SD card slots to facilitate data input/output tasks such as flight plan and database uploading or critical flight data downloads. The system takes advantage of the latest in display, computer processing, and digital data bus technology to provide a high degree of redundancy, reliability, and flexibility.



BELL 525 FLIGHT DECK

System	Description
Four-display system	Four 12" flat panel high-resolution LCDs, interchangeable for Primary Flight Display (PFD) or Multi Function display (MFD)
Flight Instruments	Integrated on PFD with stand-by Flight Display
Engine Instruments	Integrated on PFD / MFD with Power Situation Indicator (PSI), Engine Indication System (EIS), fuel flow, automated power assurance check
EICAS & Audio Alerts	Engine Indicating and Crew Alerting System (EICAS) integrated on PFD / MFD Audio alerts integrated into intercom system
COM/NAV	Dual COM / NAV / GPS, WAAS, Mode S Transponder with Extended Squitter (ES), ADS-B out, FMS, auto-tuning
Situational Awareness	Integrated on PFD / MFD, HTAWS, Synthetic Vision System, Moving Map, Fuel and NAV range, Tail Rotor Camera display on MFD, optional TCAS II with ADS-B in is available
Intercom	16-place ICS with recorder / playback, Headsets have Bluetooth support for phones, Garmin MP3 jack (customizing), 3D Audio
Touch Screen Display Controllers	Two GTC 575H infrared touch screen controllers

Garmin G5000H™ Avionics Flight Deck

The basic ship main components of the Garmin G5000H™ Integrated Avionics system include:

- Four 12" GDU 1250WH high-resolution LCD displays
- Two GTC 575H infrared grid touchscreens with "icon-identified touch keys"
 - Allows usage with gloves
 - Shallow menus keep "clicks" to a minimum
- Two GIA 6300 Integrated Avionic Units, including:
 - GPS / WAAS Receiver
 - VHF COM Transceiver
 - VHF NAV and Glideslope Receivers
 - Aural Alert Generation
 - Marker Beacon Receiver
- Three GEA 7100 Engine and Airframe Unit (signal processing of engine parameters and major system sensors)
- GRA 5500 Radio Altimeter
- GTX 3000 Mode S Transponder with Diversity and Extended Squitter
- GDL 59H Flight Parameter Recorder and Wi-Fi Datalink
- GMC 7300 Autopilot Mode & Backup Controller
- Three GSD 41 Data Concentrator Units
- L3 GH-3900 Standby Flight Display
- Three GDC 7400 Air Data Computer (ADC)
- Three GRS 7800 Attitude Heading and Reference System
- Three GMU 44 Magnetic Sensing Units

DISPLAYS

The Garmin G5000H™ flight deck presents critical flight information to the pilot at a glance for greater situational awareness, simplicity and safety. The pilot can easily and quickly select the information formats to display on the open, clutter-free, interchangeable Primary Flight Display (PFD) and Multi Function Display (MFD). The Power Situation Indicator (PSI), located in the lower left-hand corner of the PFD provides a compact, easy to interpret summary of the aircraft's power indications and limits.

The displays accept HD-SDI (Digital Video), NTSC and PAL format composite video signals from external sources, including the Bell 525's standard configuration Tail Rotor Camera and optional imaging devices such as multi-sensor camera thermal imaging systems for Search and Rescue (SAR) operations.

Primary Flight Display (PFD) Typical User Selected Formats: The PFD displays all major flight parameters in an intuitive, easy to scan layout: Attitude, Airspeed, HSI, Altitude and VSI. Primary and inset screens can be user-selected to display a variety of additional functions, including "Pathways in the Sky", Flight Path Vector, Synthetic Vision and HTAWS.



PFD Main Screen.

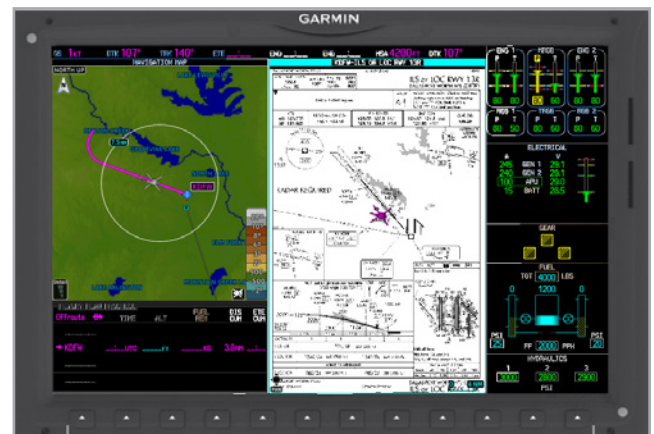

MFD (Moving map/approach/EIS display shown).

Garmin G5000H™ Avionics Flight Deck

POWER SITUATION INDICATOR (PSI)

The PSI, shown in the red circle, is a single indicator section of the PFD that provides the pilot quick information about power settings. The color-coded parameter display automatically highlights normal performance (green), near limits (yellow) or exceedance (red).



Power Situation Indicator (PSI).

COMMUNICATIONS AND NAVIGATION

Each of the standard configuration dual Garmin GIA 6300H Integrated Avionics Units include a GPS/WAAS receiver, VHF COM Transceiver and VHF NAV, Glideslope and Marker Beacon receivers. It also contains an audio processor, eliminating the need for the Garmin GMA350, used for the aural alerts for Aural Alert Generation. The GIA6300H includes a cockpit ICS, pilot and copilot volume control and dual stereo entertainment inputs. The COM interface supports up to five (5) transceivers and the NAV interface supports up to five (5) radios. It also features two (2) entertainment inputs (MUSIC 1 and MUSIC 2), with identical streaming content from the optional GDL 69H XM Radio Datalink [1]. A 3.5 mm front panel mini-jack on the can be used as an entertainment input or as a telephone input when the optional GSR 56H Iridium® Voice/ Data Transceiver [2] is installed.

The GDL 59H Datalink Management Unit provides a high speed data link between the aircraft systems and ground computers using 802.11 g (“Wi-Fi”) while the aircraft is on the ground, and a required interface to the optional GSR 56H Iridium® Voice/Data Transceiver.

- Notes: [1] Subscription to XM Satellite Weather and/or Radio is the responsibility of the helicopter owner/operator.
 [2] Subscription to Iridium® Voice/Data service is the responsibility of the helicopter owner/operator.

Garmin G5000H™ Avionics Flight Deck

EXTENDED SQUITTER (ES) MODE S TRANSPONDER

The GTX 3000H Extended Squitter (ES) Mode S Transponder functions are controlled by the PFD display, and support European Mode S mandates for Extended Squitter, Elementary Surveillance and Enhanced Surveillance. Using 1090 MHz extended squitter (ES) transmission, the GTX 3000H broadcasts details such as your accurate, GPS-calculated position, flight ID, altitude, velocity, climb/descent and heading information to air traffic control (ATC) ground stations at the rate of once per second – far faster than traditional radar tracking. The net result is that ATC gets a far more accurate picture of what’s happening in the sky and allowing them to safely reduce separation minimums for more efficient flights. Where ground stations are not yet capable of receiving extended squitter data, the GTX 3000H will still operate with traditional ATC protocols as a Mode A, C or S transponder.

Combined with the optional GTS8000H, this gives the Bell 525 G5000H™ flight deck full Traffic Collision Avoidance System (TCAS) ability.

GARMIN SOFTWARE FEATURES

Most aircraft systems are considered “Under Glass” and can be accessed and controlled through the GTC 575H touch screen.

- Electronic Circuit Breakers
- Windshield Wiper Control
- Control of Cabin and Crew Lighting
- Control of External Lighting
- Video Cameras
- Environmental System
- Static Oil Level Sensors

Other software features that reduce pilot workload and simplify maintenance are:

- Weight and Balance
- Hover Performance
- Aircraft System Tests
- Maintenance Diagnostics

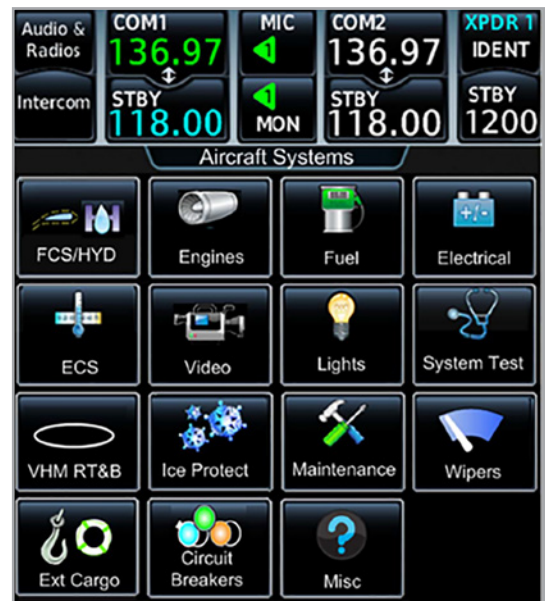

Garmin GTC 575H touch screen.

OPTIONAL EQUIPMENT ENHANCEMENTS

The following optional kits are available to further enhance the capabilities of the Bell 525’s integrated avionics system.

Flight Stream 510: Memory card that provides Wi-Fi and Bluetooth connectivity when installed in the Garmin flight deck. Flight Stream can connect with up to two mobile devices operating the Garmin Pilot App. This allows for wireless flight plan imports and exports, wireless database updates, and provides Garmin Connex Data to the smart device. This data includes GPS information, attitude/heading, traffic information (with TCASII kit), XM weather and radio controls (with GDL69 kit), and text messaging (with GSR56H kit).

GDL 69AH XM Weather Radio Datalink: A remote-mounted XM satellite radio receiver capable of receiving digital datalink weather and digital audio entertainment from an XM satellite. XM Weather and Radio operate in the S-band frequency range to provide continuous uplink capabilities at any altitude throughout North America. An individual 3rd party XM/WX subscription is required to receive XM/WX data signals. Subscriptions are available for either weather or digital audio entertainment services separately or for both services

Garmin G5000H™ Avionics Flight Deck

GSR 56H Iridium® Voice/Data Tranceiver: Provides low speed data transmission via the Iridium® satellite network supporting both Iridium® RUDICS (Internet) or Iridium® Short Burst data formats, fully integrated satellite phone functionality which can be dialed through the MFD, SMS Text Messaging, and Worldwide Weather capability. Subscription to Iridium® Voice / Data service is the responsibility of the helicopter owner / operator.

GTS 8000 TCAS II: The GTS Traffic Alert and Collision Avoidance System (TCAS II) is designed to help in the detection and avoidance of other aircraft. The GTS 8000 is a traffic surveillance system that uses active interrogations of Mode A/C/S transponders to predict incursions into the protected volume of airspace and provide Traffic Alerts (TAs) and Resolution Advisories (RAs) to the pilot independent of the air traffic control system.

GWX 80H Weather Radar: Bringing full-color storm cell tracking to your G5000H™ MFD, this doppler-capable weather avoidance tool combines excellent range and adjustable scanning profiles with precision target definition for accurate, easy-to-interpret, weather analysis in the cockpit. With pilot-adjustable horizontal scan angles of up to 120°, you can easily focus scanning on the areas you want to watch, while vertical scanning lets you focus on storm tops, gradients and cell buildup at various altitudes. Plus, Weather Attenuated Color Highlight (WATCH™) can identify areas beyond the radar's capability that may contain even more hazardous areas of precipitation. Additional GWX 80H options include:

- 3-D volumetric scanning
- Hail and lightning prediction
- Ground/sea clutter suppression
- Turbulence detection
- Predictive windshear detection

Pursuit of Safety through Technology

SITUATIONAL AWARENESS

- Canted tailboom/rotor allows for horizontal hover that gives pilots “over the nose” viewing
- Great crew peripheral viewing since there is no structural obtrusions from cockpit doors
- Hoist, cargo hook, tailrotor, and baggage bay camera, accessory kits
- Awareness Reactive Control - Horizon™ Flight Deck

INTEGRATED VEHICLE HEALTH MANAGEMENT (IVHM)

- IVHM capabilities standard – Health Usage Monitoring System (HUMS), Flight Data Monitoring (FDM) data collection, extensive Line Replaceable Unit (LRU) fault monitoring
- More advanced capabilities than other aircraft – health alerts via satellite (kit), wireless download, more monitored systems, extensive RFID tags
- Integrated off-board ecosystem:
 - New ground station with direct link from fault codes to electronic tech pubs
 - Data integration with customer maintenance management systems
 - Bell Enterprise analysis and support services

ROBUST TRANSMISSION DESIGN

- Absence of high speed planetary gear
- Independent systems alleviate total system loss
- Optimized case design for maximum heat dissipation
- Heat tolerant materials for primary torque components

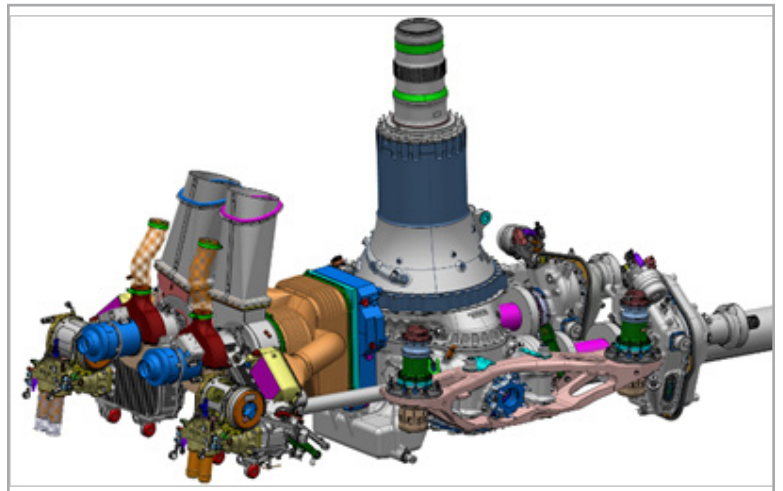

Robust transmission design.

CORROSION AVERSE DESIGN

- Maritime airframe corrosion protection included in basic aircraft configuration
- Zinc-Nickel plating on exposed steel
- Transmission housings utilize aluminum and corrosion resistant magnesium with tagnite coatings

STATE OF THE ART MANUFACTURING ASSEMBLY LINE

- Electronic production instructions
- Ergonomic tooling enhances quality and safety
- Computer designed aircraft and tooling make assembly more precise and efficient

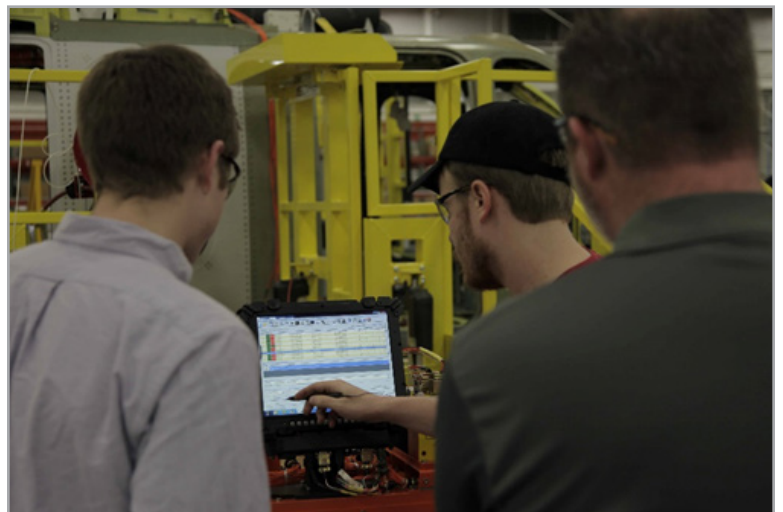

State of the art manufacturing assembly line.

Bell 525 Maintenance Program

DESIGNED THROUGH MAINTENANCE STEERING GROUP - 3 (MSG-3)

Bell understands the importance of aircraft reliability to meet your mission needs. That's why our maintenance philosophy is to streamline maintenance requirements to ensure low direct operating costs, low direct maintenance costs, and improved reliability by utilizing the Maintenance Steering Group – 3 (MSG-3) while increasing occupant safety.

The Bell 525 is the first rotorcraft designed utilizing the “Volume 2” of the MSG-3 process. This volume was specifically developed for rotorcraft system analysis in order to account for the environmental deterioration and accidental damage of the rotors and drives system components. The helicopter maintenance schedule (MSG-3) was developed on Bell 525 with the support of the Aviation authorities, mainly Transport Canada (TC), the Federal Aviation Administration (FAA) and the European Aviation Safety Agency (EASA).

During the Customer Maintenance Advisory Panel (CMAP) meetings, the team analyzed every aircraft system, including airframe structure and wiring installation, to determine the failure modes, criticality, ease of detection, level of inspection required and the ideal recurrence of inspection. This is where the varied experience of the team came in to play; Aircraft Maintenance Engineers (AME) / Airframe and Power Plant (A&P) technicians also provided input as to the system detailed functions and used their many years of experience in aircraft operation, respectively. From this resulted a maintenance schedule that requires 35% less maintenance man hours versus a comparable aircraft, thus improving the cost of ownership for the Bell 525. The following are excellent features derived through MSG-3 for the Bell 525.

APPROVED MAINTENANCE PROGRAM (TC)

- First rotorcraft to use “Volume 2” MSG-3 Process, specifically for rotorcraft system analysis

CERTIFICATION THROUGH MSG-3 PROCESS

- Same process used by commercial airlines to ensure continued airworthiness
- Determines how and when maintenance will be performed
- Helicopter designed and built for maintenance

ACCESSIBLE PANELS TO AIRCRAFT SYSTEMS

- Reduce scheduled inspection repeats
- Only inspect what needs to be inspected, saving time and cost

MAINTENANCE PROGRAM

- Minimum 400-hour inspection intervals
 - 800 hours/12 month zonal inspection program introduced
- Life Limited Parts
 - Composite components - on condition
 - Metallic components - 10,000 + hours (goal)
 - Elastomeric components - 5,000 hours (goal)

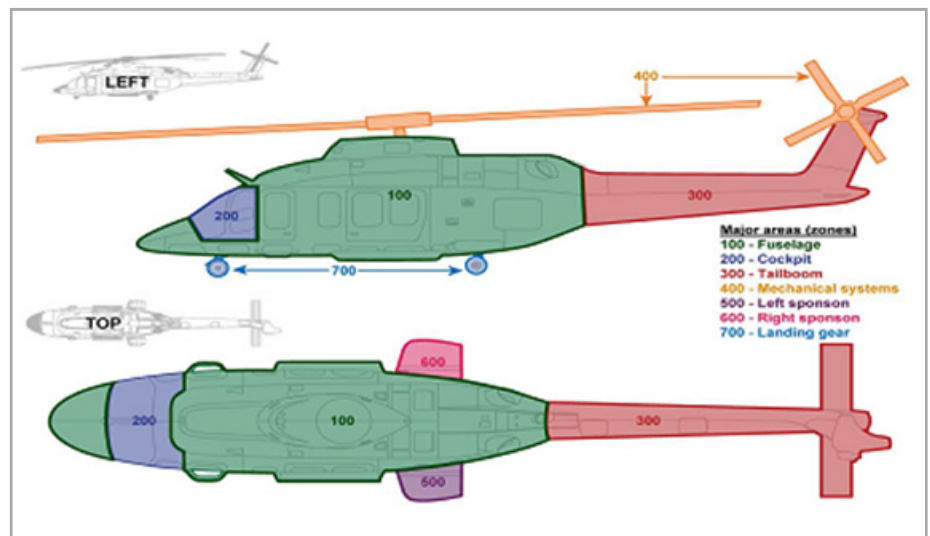

Bell 525 MSG-3 Maintenance Zones.

Seating and Interior

CREW SEATING

Two ergonomic, energy attenuating seats, with adjustable lumbar support, each equipped with a black seat belt, double strap shoulder harness and inertia reel (4-point harness), are located in the cockpit. The seats are mounted on a J-track that rotate seats inboard to allow the pilots to share the exit with the first row of passengers. This creates a much more unobstructed field of view in front of the aircraft. The absence of cockpit doors and associated structures also removes weight and maintenance upkeep. The color and upholstery material for the seats and interior trim of the cockpit match that which is selected for the cabin.



Ergonomic, Energy Attenuating Crew Seats.

Seating and Interior

16 PASSENGER SEATS KIT

The passenger seats incorporate fixed headrests, removable back & seat pan cushions, lumbar support, life vest storage and a four point restraint harness with inertia reel. All seats will have energy attenuation and provide protection and restraint of occupants (passengers) in normal flight, emergency states and dynamic landing conditions. The seats are non-adjustable and mounted with quick disconnect fittings in stationary positions. The standard Oil and Gas Producer (OGP) configuration will be sixteen extra wide (20 in) passenger seats, with three rows of four seats facing forward and one row of four seats facing aft. This configuration allows occupants to egress quickly in case of an emergency (no person is more than one seat away from an exit).

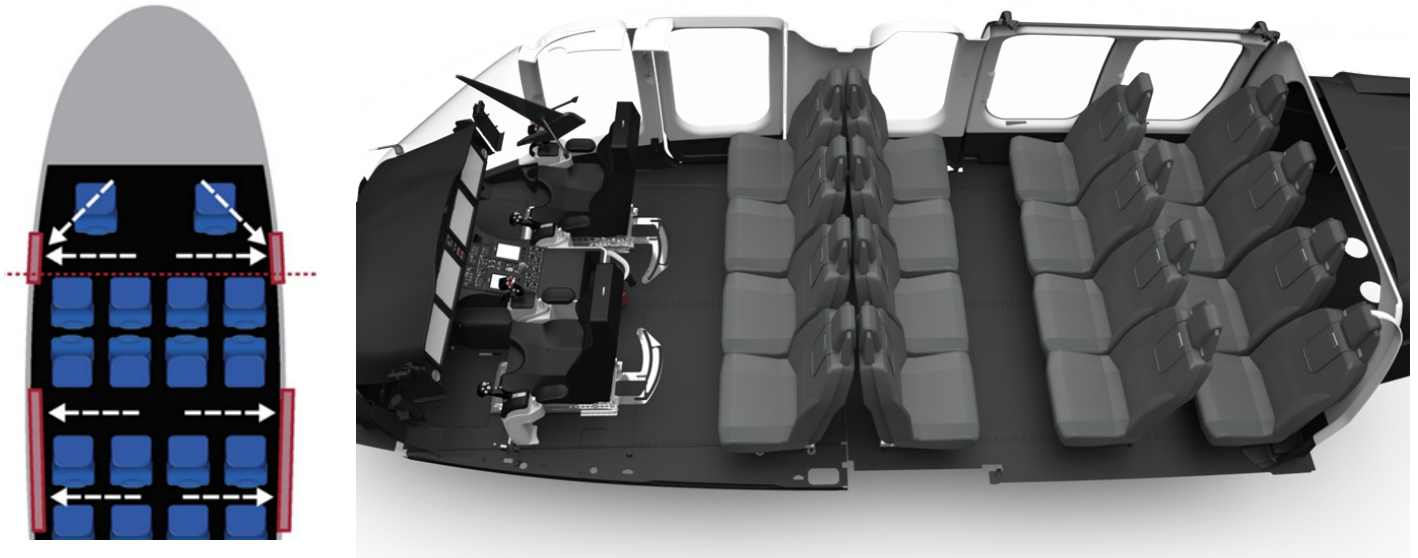

Bell 525 Interior Layout.

STANDARD INTERIOR TRIM

Standard interior panels include a reading light and air conditioning lever for each passenger (16 total) as well as (6) large ambient lights. Each passenger can control his/her reading light and the direction of air flow from a rectangular louver. Soundproofing is incorporated within the interior panels to achieve a 90 dB noise level for each passenger and crew member seated in the cabin and cockpit. The panels integrate emergency exit lighting above the doors and egress pathways. Standard interior also includes multiple grip handles to aid in ingress and egress at door locations and throughout the cabin and cockpit. Several stowage compartments are available for the crew. Provisioning for addition of other interior kits are included within the panels for ease of installation.

Mission Profiles

CORPORATE

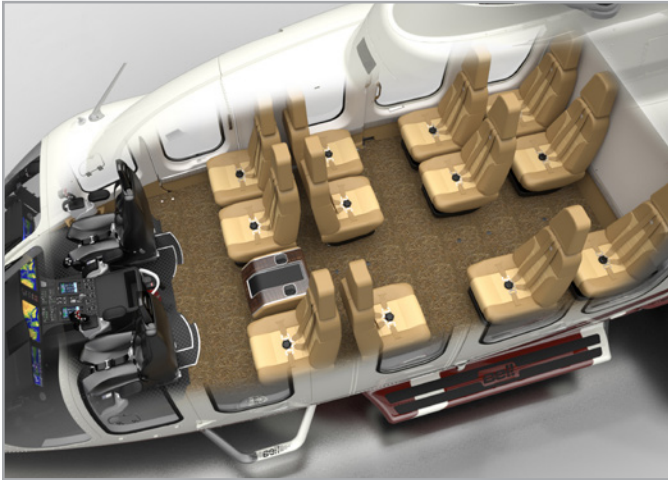

Best-in-class for Low Noise and Vibration.

The Bell 525's best-in-class cabin volume and unrivaled configuration flexibility provides comfortable corporate / VIP transportation. With the Garmin G5000H, Bell 525 pilots have superb situational awareness, further enhancing the safety of flight. The Active Vibration Control System kit provides passengers with an unprecedented ride quality for a rotorcraft.

OFFSHORE TRANSPORT



Superior Payload and Range.

The Bell 525's payload and range performance, along with its spacious cabin and baggage bay volume makes it a game-changer for the energy industry, especially for deep-water missions. Superb economics, combined with an airframe designed for reliability make the Bell 525 the number one choice for all offshore operations.

HEMS



Fast First Responder.

When speed, cabin flexibility and unparalleled crew situational awareness are essential, the Bell 525 delivers. The Garmin G5000H improves operational safety in unforgiving conditions, especially when lives are at stake.

SAR



Superior Payload and Range.

The Bell 525 SAR configuration is furnished with all of the mission configuration needed to meet SAR requirements. By sharing a common floor design with the offshore transport configuration, the modular can be rapidly reconfigured from SAR to 16 passenger transport.

Bell 525 Standard Configuration

AIRFRAME

Hybrid Composite / Metallic Structure with composite side panels and aft fuselage skins

Doors (four), one hinged door on left hand (L/H) & right hand (R/H) side, Sliding doors on the L/H & R/H sides, all doors are constructed of composite material

Landing gear, retractable wheels with independent brakes

Locks for cabin doors and luggage compartment

Baggage bay (128 ft³ [3.6m³]), with two composite doors one on each side

Provisions for jacking and platform mooring

Tail boom, Carbon/BMI monolithic structure with vertical fin and horizontal stabilizer

Baggage bay smoke detector

INTEGRATED AVIONICS SYSTEM with GARMIN G5000H™ SUITE

Four 12.1" high resolution display units, providing Primary Flight Display (PFD) and Multi-Function Display (MFD) functionalities

Two integrated avionics units, each consisting of a 16-watt VHF communication transceiver with 8.33 kHz spacing, VHF navigation, WAAS GPS navigation, and glideslope receiver

Three digital Air Data Computers (ADC) with Outside Air Temperature (OAT) probes

Three Attitude Heading Reference Units (AHRS) and three magnetometer units

One mode S transponder with extended squitter and optional TCAS with ADS-B out capability

Three engine and airframe interface units

Three engine signal conditioner units

Synthetic Vision System (SVS), and Helicopter Terrain Awareness and Warning System (HTAWS) features

Integrated Engine Indication and Crew Alerting System (EICAS), including Power Situation Indicator (PSI) that provides an integrated display presentation of all critical engine parameters into a single indicator to present the power "margin" remaining

Fuel flow indication with range ring display capability

Flight Data Recording of 60 standard aircraft and engine parameters

ELECTRICAL

28 VDC System

Battery, 24 amp-hour sealed lead acid (This starts the APU.)

External power and grounding receptacle on the nose of the aircraft

Two main brushless generators (350 ampere) located on each accessory gearbox

Two Permanent Magnet Generators (PMG) for each Flight Control Computer along with main generator

Starter-generator (200 ampere) on the APU

Majority of circuit breakers are electronic, accessed through the Garmin G5000H™

Solid state voltage regulator

28 volt outlet in cockpit

Three heated pitot tube and static ports

LED Lighting:

- Anti-collision strobe

- Cockpit lights

- Instrument lights

- Landing and position lights

Circuit Breaker and electrical provisions for 16 factory kits

Integrated/automated electrical load management

INTERIOR

Standard interior plastic panels with handholds for ingress/egress

Large LED cabin lighting and crew lighting

Decals and exit lighting/labels

16-place LED reading light and air conditioner louver

Soundproofing is incorporated within the interior panels to achieve a 90 dB noise level

LOOSE EQUIPMENT (not included in empty weight)

Garmin Pilot's Handbook

Garmin Cockpit Reference Guide

Covers:

- Engine inlet

- Exhaust stack

- Pitot tube

Bell 525 Standard Configuration

LOOSE EQUIPMENT (continued)

Manuals:

Rotorcraft flight manual
 Aircraft log book
 Engine log book
 Aircraft maintenance manuals*
 Fault isolation manual
 Wiring diagrams
 Engine maintenance manual
 Engine operating manual
 Engine parts manual
 Ground station software (aircraft data display)

Tie-down assemblies, main rotor and tail rotor

POWERPLANT

Two General Electric CT7-2F1 gas turbo-shaft engines with dual FADEC

Auxiliary Power Unit (APU), Honeywell RE100BR provides bleed air for the ECS and engine starting

Fire suppression using dual Halon pressurized bottles

Five rupture resistant fuel cells with 6 removable boosted (BLDC) fuel pump cartridges

Five probe gauging system mounted to sump plate for easy maintenance

Auxiliary fuel tank provisions

Compressor wash provisions

ROTORS and CONTROLS

Main rotor, fully articulated rotor with five composite blades

Tail rotor, fully articulated with four composite blades

Triplex hydraulic systems & flight controls with no degradation in flight capability following a single fault

Fly-by-wire flight controls - interconnected sidarm controllers with tactile cueing for envelope protection

Advanced control laws for improved handling qualities in adverse environments

Rotor brake

TRANSMISSION DRIVE SYSTEM

Soft mounted LIVE pylon isolation system

Main transmission with 2 freewheeling units, 4 chip detectors with automatic debris burn & history logging

One-piece titanium main transmission input driveshaft assemblies with anti-flail. Kamatics Tufflex input driveshafts to accessory gearboxes

Tail rotor gearbox (sight gage and monitored chip detector, replaceable filter element, automatic debris burn and history logging)

Intermediate gearbox (sight gage and monitored chip detector, replaceable filter element, automatic debris burn and history logging)

Reduction gearbox (L/H & R/H, sight gage and monitored chip detector, automatic debris burn and history logging)

Accessory gearbox (L/H & R/H, sight gage and monitored chip detector, automatic debris burn and history logging)

Gearbox mounted oil cooler along with 2 additional stand alone coolers with shaft driven blowers

All gearboxes have oil level monitoring visible to crew under glass on the G5000H flight deck

* Aircraft maintenance manuals are available on ePubs located here: <http://www.bellhelicopter.net>

Bell 525 Kits

Additional kits and STC items may be available for factory installation. Please consult sales or contract personnel regarding special needs prior to selection of final configuration.

ACCESSORIES

Kit Description
STANDARD
Camera – Tail Rotor
Closed Circuit Refuel
Hooks – Headset and Flight Helmet
Pressure Adapter Refuel
Step – Faired
Sun Visor – Cockpit
Traffic Collision Avoidance System
Window – Cabin, Standard, Dark Tint
Window – Crew, Push-out, Light Tint
Windsheild – Unheated, Clear
Wire Strike
OFFSHORE TRANSPORT RECOMMENDED
ADELTA (Auto Deployable ELT)
Air Conditioning
Baggage Fire Suppression
Engine Inlet Barrier Filter
Floats
Interior Panels, Doors and Baggage Bay Partition
Life Raft – 18-person
Seats – 16-passenger
Weather Radar (color) / Offshore Approach
Window – Cabin, Push-out, Dark Tint
Windshield Washer
HEELS Lighting
CORPORATE RECOMMENDED
Air Conditioning
Engine Inlet Barrier Filter
Interior - Corporate (8-10-12 Passenger*)
Weather Radar (color) / Offshore Approach
Windshield Washer

*Corporate Interior includes: Soundproofing, Electrochromic windows, Crew Charging Stations and Cabin Inverters, 4 Color Options

Bell 525 Kits

ACCESSORIES

Kit Description
SAR RECOMMENDED
ADELT (Auto Deployable ELT)
Air Conditioning
Cargo Hook (Electrical Provisions)
Cargo Hook (Structural Provisions)
Engine Inlet Barrier Filter
Floats
Hoist, [Full Kit - HEC]
Life Raft – 7-person
Light – High Power Search
Litter – 1 person
Radio - HF
Radio Altimeter 2
SAR Software Upgrade
Weather Radar (color) / Offshore Approach
Window – Cabin, Push-out, Dark Tint
Windshield Washer

Bell 525 Kits

OPTIONAL ACCESSORIES

Kit Description
AIRFRAME
APU Barrier Filter
Engine Inlet Barrier Filter
Step – Tube Style
Window – Bubble Cockpit
Window – Cabin, Push-out, Dark Tint
Window – Cabin, Push-out, Light Tint
Window – Cabin, Standard, Light Tint
Window – Crew, Push-out, Dark Tint
Windshield – Heated, Clear
Windshield – Heated, Light Tint
Windshield – Unheated, Light Tint
Windshield Washer
AVIONICS
ADELTA (Auto Deployable ELT)
Automatic Direction Finder 1
Beacon – SART
Camera – Baggage Bay
Camera – Cargo / Ground Hook
Camera – Main Rotor Clearance
Direction Finder – V/UHF
DME – Triple Channel
Enhanced Vision System
EO/IR Camera System
Flight Stream 510
Iridium Satellite Voice, Data, and International Weather
Lightning Detection
Loud Hailer
Map – Street Level Digital
Public Address – Cabin
Radar – Airborne Search
Radio – HF
SAR HIRF Treatment
SAR Software Upgrade
Target Location
Target Location Data Transfer

Bell 525 Kits

OPTIONAL ACCESSORIES

Kit Description
ELECTRICAL
Cargo Hook – Electrical Provisions
DC to AC Conversion
HEELS Lighting
Ice Protection – Full
Ice Protection – Limited
Light – High Power Search
Light – Landing, High Visibility, Pulsed
Light – Landing, Infrared Articulated
Radio Altimeter 2
PROPULSION
Air Conditioning
Auxiliary Fuel Tank - Baggage Bay
AVCS (Active Vibration Control System)
External Air Start
MECHANICAL SYSTEMS
Cargo Hook – Dual External Kit
Cargo Hook – Single External Kit
Cargo Hook – Structural Provisions
Fast Rope
Hoist – Dual, Bolt On Parts
Hoist – Dual, Full Kit, HEC
Hoist – Dual, Provisions
Hoist – Single, Bolt On Parts
Hoist – Single, Full Kit, HEC
Hoist – Single, Provisions
INTERIOR
Floats
Interior – Corporate (with 8 Passenger Seats and Sound Proofing)
Interior – Fire
Interior Panels, Doors and Baggage Bay Partition
Life Raft – 18-person
Life Raft – 7-person
Litter – 1-2 person
Seats – 16-passenger
Seats – High Density
Separation Curtain – Angled Panel, Custom
Separation Curtain – Straight

Customer Support and Services

At Bell, we understand that our responsibility to our customers extends far beyond the aircraft sale. We are committed to providing the resources necessary to ensure the safe and reliable operation of our products, and we will be with you at every step of your aircraft's lifecycle. Consistently voted the #1 Customer Support & Services organization in the industry, Bell offers a wide range of products and services to support your mission requirements.



SUPPORT AND SERVICE OFFERINGS

- 2** Straightforward Customer Advantage Plans (CAP) covering basic aircraft configuration with optional coverage for non-standard kits
- 8** Bell service centers around the world with wide ranging maintenance, repair and overhaul capabilities
- 80+** Bell Training Academy employees with extensive experience, offering the most advanced pilot and maintenance courses

- 4,000** Parts offered through the Aeronautical Accessories brand
- and**
- 1,200** Unique Supplemental Type Certificates (STCs), all of which comply with FAA regulations and meet rigorous internal quality standards
- 100+** Bell authorized Customer Service Facilities (CSFs) with the ability to perform a wide range of aircraft services

Customer Support and Services

CUSTOMER ADVANTAGE PLANS (CAP)

Customer Advantage Plans (CAP) safeguard your direct maintenance costs and provide the ultimate in cost predictability. The plans protect your investment and provide confidence of knowing you're backed by the industry leader in customer support. With coverage options for non-standard kits, our customers experience the Bell Advantage.

SIMPLE COMPREHENSIVE PLANS

Bell offers two simple Customer Advantage Plan options: Standard and Premier Plans.

Both offer holistic coverage of the standard helicopter configuration, with optional coverage for non-standard kits. Standard and Premier Plans are both designed to provide peace-of-mind that your aircraft is protected from day one of your aircraft ownership. Why overcomplicate your OEM support?

***Don't just think you're covered...
Know it.***

Program Benefits

- DMC competitive
- Optional non-standard kit coverage
- Preferred rates for aircraft serviced by any of the 100+ Bell Customer Service Facilities (CSFs)
- Streamlined budgeting
- Residual value protection
- Improved financing terms
- Transferable upon aircraft resale*
- Fleet customers may be eligible for no "Buy-Ins"

Bell Global Network Advantage

Bell has the largest and highest rated service network in the industry. CAP members who use a Customer Service Facility for their local maintenance are rewarded with preferred "in-network" rates for their aircraft.

Premier Access to Increase Aircraft Availability

Customer Advantage Plan members have preferred access to Bell's dedicated rotatable pool of parts. This inventory reduces traditional repair or replace turnaround times.

**Upon sale of aircraft, any remaining funds in the aircraft's Premier CAP account may be transferred with execution of new contract.*

CUSTOMER ADVANTAGE PLAN FEATURES

		Premier	Standard
Typical Customer	Aircraft ownership	New aircraft or fleet customers	New aircraft only
	Years of aircraft ownership	5+	<5
	Annual flight hours	High	Low
Coverage	Standard helicopter configuration parts	<input checked="" type="checkbox"/>	<input checked="" type="checkbox"/>
	Optional coverage for kits installed by Bell	<input checked="" type="checkbox"/>	<input checked="" type="checkbox"/>
	Optional OEM engine coverage	Varies by model	
	Parts used for scheduled maintenance	<input checked="" type="checkbox"/>	
	Parts used for unscheduled maintenance	<input checked="" type="checkbox"/>	<input checked="" type="checkbox"/>
	Life-limited component coverage	<input checked="" type="checkbox"/>	
	Overhauls	<input checked="" type="checkbox"/>	
	OEM-original or authorized parts	<input checked="" type="checkbox"/>	<input checked="" type="checkbox"/>
Alert Service Bulletins	<input checked="" type="checkbox"/>	<input checked="" type="checkbox"/>	

CUSTOMER ADVANTAGE PLAN FEATURES

		Premier	Standard
Contract	Minimum annual flight hours	No minimum	No minimum
	Renewable	<input checked="" type="checkbox"/>	<input checked="" type="checkbox"/> **
	Transferable	<input checked="" type="checkbox"/> *	<input type="checkbox"/>
	Preferred rates for using Bell Authorized Customer Service Facilities	<input checked="" type="checkbox"/>	<input checked="" type="checkbox"/>
	Choice pricing under warranty	<input checked="" type="checkbox"/>	<input checked="" type="checkbox"/>
Support	Access to Bell Customer Portal	<input checked="" type="checkbox"/>	<input checked="" type="checkbox"/>
	On-site technical assistance	<input checked="" type="checkbox"/>	<input checked="" type="checkbox"/>
	24/7/365 Aircraft on Ground (AOG) support	<input checked="" type="checkbox"/>	<input checked="" type="checkbox"/>

* Upon sale of aircraft, any remaining funds in the aircraft's Premier CAP account may be transferred with execution of a new contract.

** Conditions may apply

NEW AIRCRAFT COVERAGE

The Customer Advantage Plan provides the confidence of knowing you're backed by the industry leader in customer support. For new aircraft, the plans are designed to provide peace-of-mind that your aircraft is protected from day one of your aircraft ownership.

KEY BENEFITS



LOWER RATES
DURING WARRANTY



SAVINGS ON OVERALL
AIRCRAFT SUPPORT



RESIDUAL VALUE
PROTECTION ON AIRCRAFT

WARRANTY AND CAP OPTIONS

CAP COVERAGE
(In Network)

3 YEARS/
**2000 HR WARRANTY
+
*3 YEARS LABOR

CAP COVERAGE
(Out of Network)

3 YEARS/
**2000 HR WARRANTY
+
*2 YEARS LABOR

**STANDARD
WARRANTY**

3 YEARS/
**1000 HR WARRANTY
+
*1 YEAR LABOR

* year(s) total or time out on aircraft | **with CAP purchased at point of sale

To learn more about how Customer Advantage Plans can assist you with your aircraft operations, please contact CAP@bellflight.com or contact your Bell Sales Representative.

Customer Support and Services

Service Centers

The wide-ranging capabilities of our Customer Support and Services organization provides complete and seamless support - offering Bell customers the advantages of a one-stop helicopter services experience - worldwide.

With services ranging from state-of-the art helicopter customization, aircraft refurbishment and helicopter accessory options to unparalleled maintenance, repair and overhaul solutions, combined with personalized service offerings, Bell provides you with local support in every corner of the world.

VALUE ADDED SERVICES

		Piney Flats	Miami	Ozark	Singapore	Prague	Broussard	RBI Hawker (UAE)	RBL (United Kingdom)
Component Repair & Overhaul Capabilities	Expanded repair	•		•					
	Transmission	•		•	•				
	Hubs	•		•	•				
	Avionics	•		•		•			
	Rotor blades						•	•	•
	Composite panels						•		
Additional Capabilities	Aircraft customizing	•		•	•	•			
	Aircraft refurbishment	•	•	•	•	•			
	Maintenance, repair & overhaul	•	•	•	•	•			
	Upgrades & mods install	•	•	•	•	•			
	Approved installer of Aeronautical Accessories parts & accessories	•	•	•	•	•			
	Paint service	•		•	•	•			
	Field maintenance & repair	•	•		•	•	•		
	Bell maintenance training	•			•				
	Bell warranty work	•	•	•	•	•	•	•	•

Customer Support and Services

CUSTOMER SERVICE FACILITIES (CSF)

At Bell, we understand the importance of maintaining the readiness of your aircraft. That is why we are committed to providing the helicopter industry’s premier global customer support network. With more than 100 authorized facilities globally, the award-winning Bell Customer Service Facility (CSF) network is there to ensure your aircraft is ready—whenever or wherever you need it.

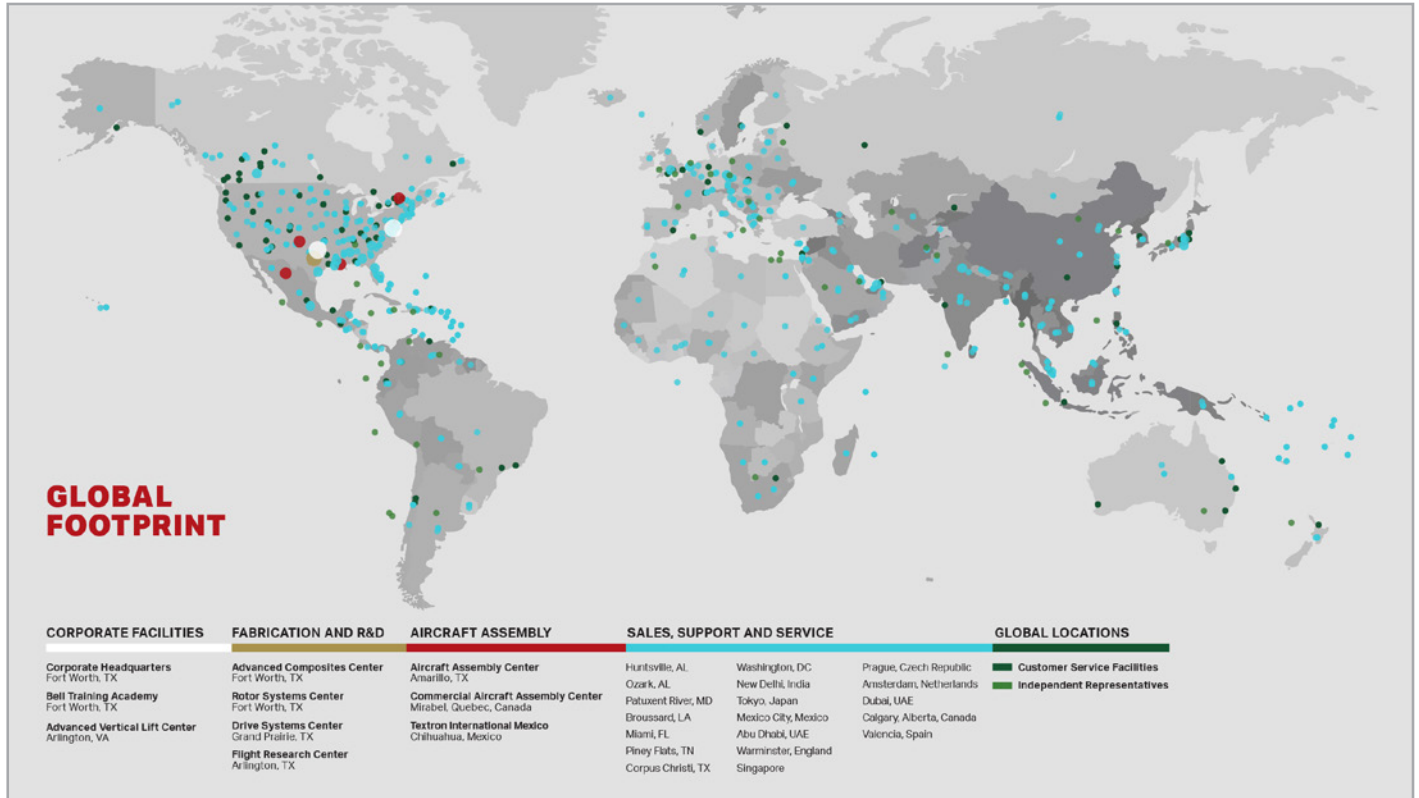

QUALITY ASSURED AND OEM APPROVED

Customers who choose an authorized CSF for maintenance, repair and overhaul work can be assured that both the staff members and the facility itself meet Bell’s stringent internal standards for quality and safety. Authorized CSFs have factory-trained maintenance technicians and are equipped with the training and expertise required to process Bell warranty claims. In addition, these facilities maintain guaranteed parts inventories to service aircraft and possess the most up-to-date technical and safety information available. All of this combines to provide in-region support you can trust.

Training

BELL TRAINING ACADEMY (BTA)

Bell's global training solutions are designed to equip customers with the knowledge and skills necessary to safely and efficiently perform their missions. Since 1946, the Bell Training Academy (BTA) has been committed to providing industry leading training programs that create better, safer flight operations. The BTA staff of highly skilled professional pilot and technical instructors leverages OEM data and expertise to deliver the finest helicopter training in the world. We continue to develop innovative programs that will take our customers' pilot and technical skills to a whole new level.

Pilot and maintenance training is complimentary with each new aircraft purchase. Supplemental, training courses are available at an additional cost.



The Bell Training Academy at Bell's headquarters in Fort Worth, Texas.

STATE-OF-THE-ART TRAINING RESOURCES

Based at the Bell headquarters in Fort Worth, Texas, the BTA combines a track record of excellence with a wide variety of industry-leading amenities.

<p>#1</p>	<p>Pilot and maintenance training consistently ranked #1 the industry.</p>	<p>375+</p>	<p>Years combined experience among Bell's technical instructors</p>
<p>25,000+</p>	<p>Square foot maintenance hangar</p>	<p>8,500</p>	<p>Average instructor pilot flight hours</p>
<p>200,000+</p>	<p>Pilot and maintenance technicians trained</p>	<p>134+</p>	<p>Countries represented by customers in every market segment</p>
<p>2</p>	<p>Full Flight Simulators for the Bell 407GX and Bell 525</p>	<p>6</p>	<p>Advanced Flight Training Devices (FTD) designed to train on seven models</p>

Training

The BTA's 80+ staff members welcome students from all over the world, and are eager to share the knowledge gained from decades of hands-on experience within the military and across other professions. Instruction can be provided in English or Spanish. Language translation is available for an additional cost.

Recognized by the European Aviation Safety Agency (EASA) as an Approved Training Organization (ATO), the BTA has the authorization to provide Part-FCL flight training courses to European customers for the 407, 212/412, 429, and 505 models, including the use of Flight Training Devices (FTD) for the Bell 407 and 429 models. A Performance Based Navigation (PBN) Generic Non-Type or 412/429 Type Rating Specific courses are also approved.

The BTA is also authorized by various international regulatory agencies for type-specific technical training of engineers / mechanics. These agencies include the Civil Aviation Authority of Singapore (CAAS), Transport Canada (TC), European Aviation Safety Agency (EASA), Australian Civil Aviation Safety Authority (CASA), Civil Aviation Administration of China (CAAC), Director General Civil Aviation of India (DGCA), and the UAE General Civil Aviation Authority (GCAA).

GLOBAL TRAINING NETWORK

With nearly 70 percent of our commercial aircraft delivered internationally, Bell understands the need for training to be readily available where our customers perform their missions. Our training centers are equipped and certified to meet the needs of our customers around the globe. We are committed to having resources where our customers operate and are investing to provide world-class, global training solutions to meet a growing customer demand.

Europe: All pilot training classes at Bell Training Academy (BTA) – Valencia, powered by TRU Simulation + Training are instructed upon the Bell 429 EASA-certified Level D Full Flight Simulator (FFS). The Bell 429 FFS by TRU offers the largest standard visual field of view and the largest standard dome radius of any simulator on the market today. Additionally the FFS offers industry-leading motion performance with high-fidelity superior accelerations, smoothness, and responsiveness powered by REALFEEL® Control Loading System and REALVibe™ Secondary Cueing System.

Bell Training Academy (BTA), Valencia, powered by TRU Simulation + Training offers three courses with plans for additional class offerings in the coming years. BTA-Valencia offers a 10-day Bell 429 EASA initial type rating and a Bell 429 recurrent course to reinforce the initial type rating. Additionally, BTA-Valencia offers wet and dry leasing that is custom tailored to each operator. For more information on wet and dry leasing please visit www.bellflight.com/training.

Singapore: BTA Singapore is approved by the Civil Aviation Authority of Singapore (CAAS), European Aviation Safety Agency (EASA), Australian Civil Aviation Safety Authority (CASA), and Director General Civil Aviation of India (DGCA), and the UAE General Civil Aviation Authority (GCAA). BTA Singapore offers regulatory classes for maintenance theory and practical training on all current Bell models and select legacy aircraft. Available courses include avionics maintenance, field maintenance and refresher courses, cable and connector training, and vibration monitoring system training.



Bell training at BHT Singapore.

Training

GENERAL INFORMATION

The operator and maintenance training provided by BTA establishes a foundation that supports mission tasks with aircraft pilot qualification.

Pilot Operator Training: Our pilot training program includes basic academics and initial flight training to transition current pilots into Bell aircraft. All training is conducted by certified Bell instructor pilots.

Maintenance Technician Training: Experience is important, however, instruction received in the classroom and training lab provides an undeniable enhancement. Facilitating more efficient maintenance manpower and improving logistics supportability ensures that the customer's Bell is operational and maintainable in all types of climate and terrain.

Academic training includes both state-of-the-art instructor-led computer presentations and hands-on maintenance training. Mechanical, electrical, and avionics training takes place in a temperature controlled shop and will include use of composite maintenance trainers and avionics bench trainers. The BTA also has operational cutaway mockups, a composite repair room, and an electrical/avionics lab. Over half of the maintenance training is hands-on, skill enhancing, and performance focused instruction. Training is determined complete, as defined by Bell, after each student demonstrates an ability to perform to the course standards for actual maintenance and operation of the equipment referencing technical manuals.

Training Aircraft: The Bell Training Academy conducts flight training in Bell OEM-owned or newly delivered customer aircraft.

Training Materials and Language: Bell provides each maintenance and pilot training candidate a hard-copy course notebook in the English language for each course conducted by BTA instructor personnel. The training materials will be sufficient to train maintenance technicians and pilots who meet the course prerequisites in the maintenance and operation of the applicable model helicopters. Course instructional electronic media, syllabi, course outlines, and company intellectual property will be considered non-deliverables.

Training Technology: Bell is leading the industry in its use of engineering technology to more effectively teach pilots and maintainers around the world. The use of 3-D rendered, high-fidelity, interactive graphics provide students an authentic representation of each component. Smart Board technology allows for independent media manipulations such as assembly and disassembly of system subassemblies and replication maintenance actions without leaving the classroom. The adoption of 3-D modeling of aircraft components and system assemblies has greatly improved training efficiency by enhancing student retention.

Student Registration: The customer is responsible for submitting an enrollment request for each training candidate via Bell's on-line registration process at www.bellflight.com/training. It is encouraged that all training be scheduled at least ninety (90) days prior to the start of each established course date to ensure space and instructor availability.

Cancellation Policy: The customer agrees to comply with the Bell Training Academy cancellation policy as set forth at www.bellflight.com/training.

Trainee Visas: Applying for and receiving a visa for students in a timely manner is the responsibility of the customer. To ensure timely approvals, students must register early.

Trainee Expenses: Arrangements and expenses associated with training, including but not limited to, air travel, ground transportation (car rental/taxi), meals, and lodging for each designated trainee will be the responsibility of the customer.

Training

TRAINING COURSES

The following table summarizes the complimentary training provided with each purchased Bell 5. Additional training options are available at www.bellflight.com/training

BELL 525 TRAINING COURSE SUMMARY

Course	Complimentary	Duration
Pilot Training		
Bell 525 Pilot Ground and Flight Procedures	1	4 weeks
Maintenance Training		
Bell 525 Field Maintenance	1	4 weeks
Bell 525 Avionics/Electrical Maintenance	1	4 weeks

COURSE DESCRIPTIONS

Please visit our website at www.bellflight.com/training for complete course descriptions.



Our Aeronautical Accessories brand offers more than 4,000 parts and 1,200 unique supplemental type certificates (STCs), allowing you to upgrade your aircraft to meet the latest mission requirements. Aeronautical Accessories offers a broad selection of competitively priced, proven replacement parts and accessories with the best and most respected customer service in the rotorcraft aftermarket industry.

INNOVATION RELIABILITY & PERFORMANCE

In aviation, innovation must be accompanied by a stringent focus on compliance to ensure your safety and that of your crew and passengers. To deliver on that commitment, Aeronautical Accessories places an uncompromising focus on safety and quality. Our components meet FAA requirements as well as exacting internal standards and are backed by an exceptional warranty—a benefit of being part of the Bell brand. In addition, we are registered under Bell as a certified ISO 9001 with AS9100 Revision D facility.

GLOBAL AVAILABILITY OF PRODUCTS

Through our global distribution and modern inventory management system, we minimize customer downtime for repairs, refurbishments and completions. Aeronautical Accessories is your solution for:

- Windows
- Interior and trim
- Landing gear
- Composites
- Safety and mission equipment
- Doors and seating
- Lighting and vision
- Fuel systems and filtration
- Floats
- Ground handling equipment

To view the full range of Aeronautical Accessories product offerings, please visit www.aero-access.com. To reach Sales & Support, please call 800.251.7094 or by email at sales@aero-access.com.

